



AIROBOT

Breathe different

Intelligent Ventilation and Smart
Heating Control Solutions
www.airobothome.com



Your home should work for you, not against you

There's no place like home. Whether it's your house, your workplace (yes, for some, that too), or any other space where you spend time with those who matter most, this is something we all understand and accept.

Hate to break it to you, but **your home might be the one holding you back without you even realizing it.** While you're doing your best, providing safety for your family, excelling at work, taking care of your body, and striving to be your best self, your home is silently wasting your money and affecting your well-being.

No one likes to hear it, but let us explain. No matter how well-built or new your home is, time takes its toll, and hidden inefficiencies start creeping in.

Ventilating your home, burning your budget?

You'd be surprised how much energy and money is wasted due to an inefficient and outdated ventilation devices. A LOT! Ventilating empty rooms is like **throwing money out the window.**

Don't even get us started on potential health implications. Did you know that **indoor CO₂ levels can rise to unhealthy levels in less than an hour?** You can ditch screens, invest in the best pillow, and follow all the sleep hygiene advice out there, but if the air you breathe is polluted, you'll still wake up exhausted, irritable, and wondering why.

Don't settle. Breathe different

No need to panic, we've got you. This is exactly what we specialize in. The **AIRobot intelligent heat recovery ventilation unit** is designed exactly to solve these problems. You're in the right place.

At **AIRobot**, we believe every home and workspace should be a sanctuary of comfort, health, productivity, and effortless living. Our vision is to eliminate hidden obstacles that undermine your well-being.

By combining advanced technology with thoughtful simplicity, we design systems that seamlessly transform indoor environments, delivering cleaner air, balanced climates, and greater efficiency.

With AIRobot, it's not just about breathing easier—**it's about breathing different.**



Let's talk action!

sales@airobothome.com

www.airobothome.com

[f](#) [in](#) [@](#) @airobotee

AiRobot L

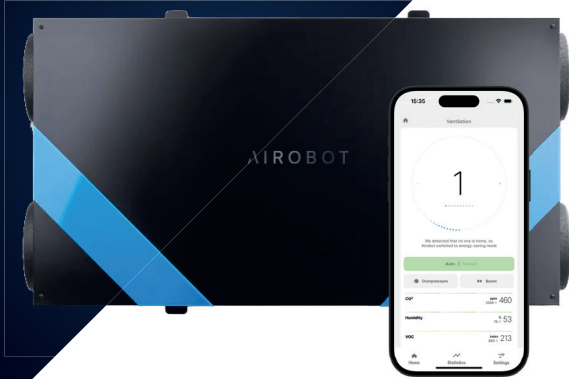

As standard equipment, includes

- constant flow
- integrated CO₂, VOC, air temperature, humidity and PM sensors
- autonomous control – smart control of fans ensures energy efficiency and good indoor air quality
- room occupancy sensing (together with energy saving mode)
- humidity detection mode.

Specifications

Installation	ceiling-mounted, horizontally
Airflow up to	L: 250 m ³ /h với 70 l/s với 120 m ² ventilated area L ERV: 200 m ³ /h với 55 l/s với 100 m ² ventilated area
Heat exchanger	HRV: plate heat exchanger with heat recovery ERV: plate heat exchanger with humidity and heat recovery
Heat recovery efficiency	L: 89%, L ERV: 77%
Filters	panel filters, ePM10 55% (M5) / outside air ePM1 55% (F7)
Power supply	1~230 VAC 50 Hz
Maximum power	1.9 kW (10 A)
Fans	2 × 83 W Radical EC Fans
Preheater (frost protection)	integrated, nominal power 1.1 kW PTC, 0–100% control
Special power SPI (L / L ERV)	0.38/0.30 W/(m ³ /h) 175 m ³ /h / 140 m ³ /h 50 Pa
Special power SFP (L / L ERV)	1.36/1.08 W/(m ³ /s) 175 m ³ /h / 140 m ³ /h 50 Pa
Condensate connection (mm)	15 mm, 3 m hose included
Colours	white, black, without metal casing

Energy labels

AiRobot L

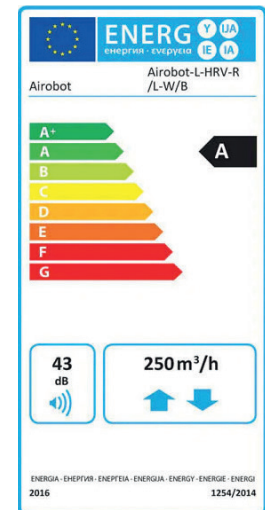

AiRobot L ERV

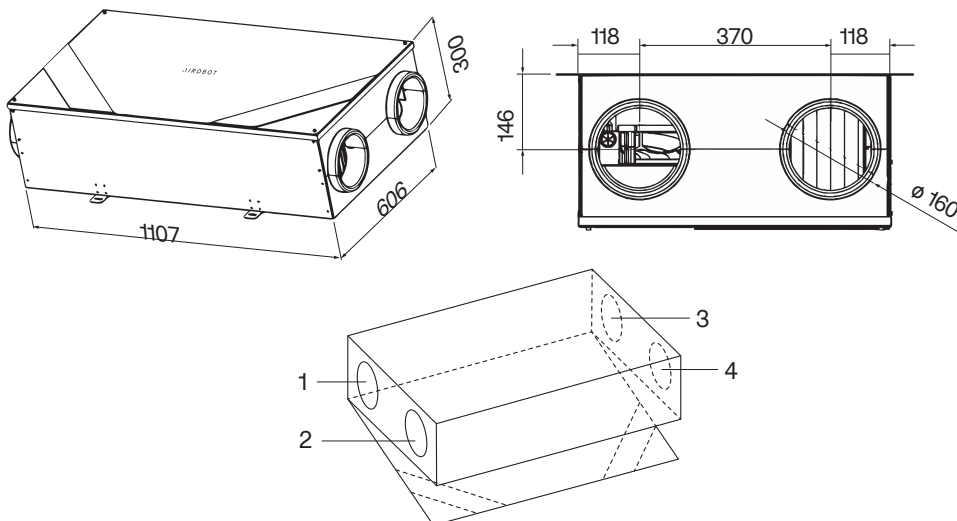
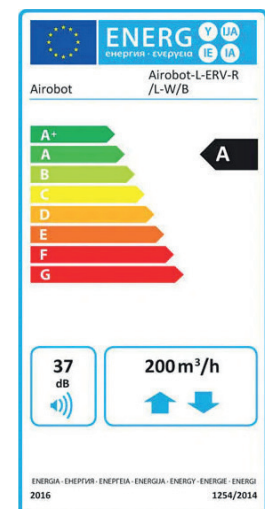

Ducts

TYPE R

1. Exhaust air
2. Outside air
3. Supply air
4. Extract air

TYPE L

1. Supply air
2. Extract air
3. Exhaust air
4. Outside air

AIRobot L5



As standard equipment, includes

- constant flow
- integrated CO₂, VOC, air temperature, humidity and PM sensors
- autonomous control – smart control of fans ensures energy efficiency and good indoor air quality
- room occupancy sensing (together with energy saving mode)
- humidity detection mode.

Specifications

Installation	ceiling-mounted, horizontally
Airflow up to	500 m ³ /h or 139 l/s or 250 m ² ventilated area
Heat exchanger	L5: plate heat exchanger with heat recovery L5 ERV: plate heat exchanger with heat and humidity recovery
Heat recovery efficiency (70% airflow)	L5: 85,6% L5 ERV: 84,7%
Panel filters	extract ePM10 55% (M5) / outside air ePM1 55% (F7)
Power supply	1~230 VAC 50 Hz
Maximum power	2.2 kW (16 A)
Fans	2 × 170 W Radical EC
Preheater (frost protection)	integrated, nominal power 1.5 kW PTC, 0-100% control
Special power SPI (L5 / L5 ERV)	0.3/0.3 W/(m ³ /h) ^{350 m³/h / 350 m³/h}
Special power SFP (L5 / L5 ERV)	1.08/1.08 W/(m ³ /s) ^{350 m³/h / 350 m³/h}
Condensate connection (mm)	15 mm, 3 m hose included
Colours	white, black
Packaging	1200 × 310 × 800, weight 70 kg

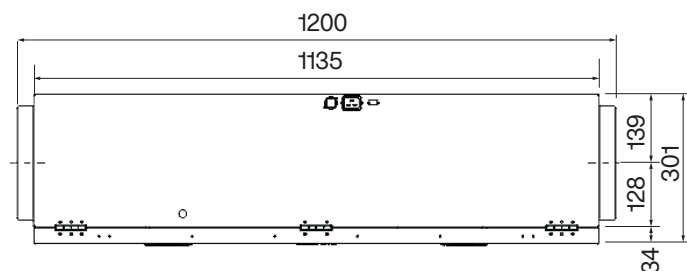
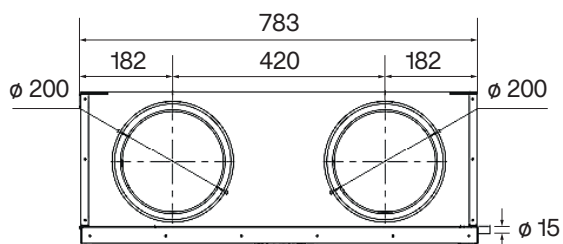

Ducts

TYPE R

1. Supply air
2. Extract air
3. Exhaust air
4. Outside air

TYPE L

1. Exhaust air
2. Outside air
3. Supply air
4. Extract air

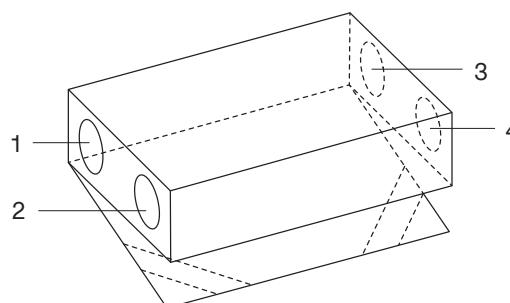

AIRobot V3



As standard equipment, includes

- constant flow
- integrated CO₂, VOC, air temperature, humidity and PM sensors
- autonomous control – smart control of fans ensures energy efficiency and good indoor air quality
- room occupancy sensing (together with energy saving mode)
- humidity detection mode.

Specifications

Installation	wall-mounted, vertically
Airflow up to	300m ³ /h or 83 L/s or 140 m ² ventilated area
Heat exchanger	HRV: plate heat exchanger with heat recovery ERV: plate heat exchanger with humidity and heat recovery
Heat recovery efficiency (70% airflow)	V3: 89%, V3 ERV: 84%
Filters	extract air ePM10 55% (M5) / outside air ePM1 55% (F7)
Power supply	1~230 VAC 50 Hz
Maximum power	1.9 kW (10 A)
Fans	2 × 83 W RadiCal EC
Preheater (frost protection)	integrated, nominal power 1.35 kW PTC, 0–100% control
Special power SPI (V3 / V3 ERV)	0.31/0.31 W/(m ³ /s) ^{219 m³/h / 140 m³/h 50 Pa}
Special power SFP (V3 / V3 ERV)	1.12 / 1.12 W/(m ³ /s) ^{219 m³/h / 140 m³/h 50 Pa}
Condensate connection (mm)	32 mm
Colours	white, black
Packaging	80 × 60 × 60 cm, weight 45 kg

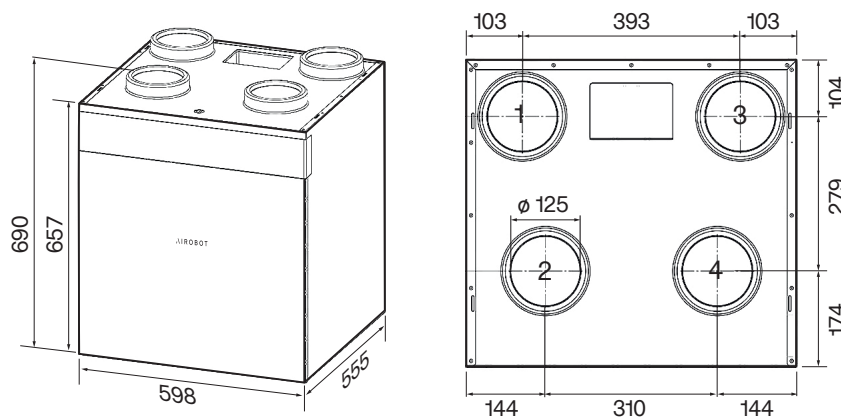

Ducts

TYPE R

1. Supply air
2. Extract air
3. Exhaust air
4. Outside air

TYPE L

1. Exhaust air
2. Outside air
3. Supply air
4. Extract air

Energy labels

AIRobot V3

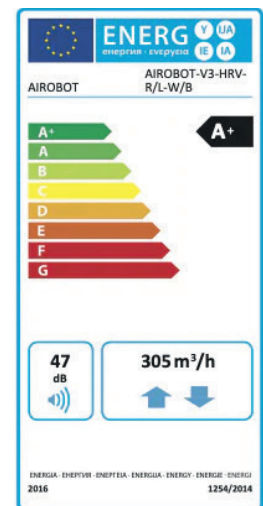

AIRobot V3 ERV

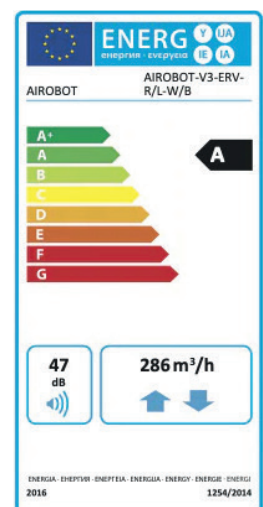

AiRobot V4

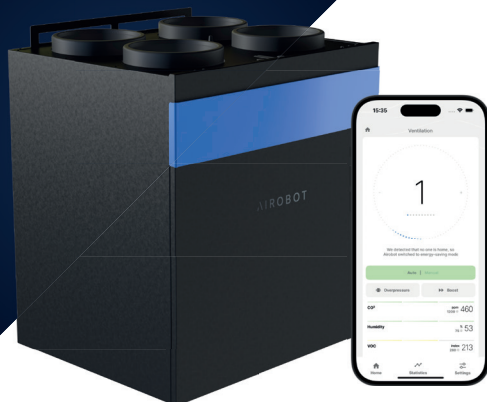

As standard equipment, includes

- integrated CO₂, VOC, air temperature and humidity sensors
- autonomous control – smart motor control ensures pleasant indoor air and energy efficiency
- room occupancy sensing and energy-saving mode
- humidity detection mode
- overpressure and boost modes

Specifications

Installation	wall-mounted, vertically
Airflow up to	400 m ³ /h or 111 l/s or 170 m ² ventilated area
Heat exchanger	HRV: plate heat exchanger with heat recovery ERV: plate heat exchanger with humidity and heat recovery
Heat recovery efficiency (70% airflow)	V4 ERV: 80.0 %, V4 HRV 90.5%
Filters	exhaust air ePM10 55% (M5) / outside air ePM1 55% (F7)
Power supply	1~230 VAC 50 Hz
Maximum power	2.1 kW (16 A)
Motors	2 × 90 W Radical EC
Preheater (frost protection)	Integrated, nominal power 1,5 kW PTC, 0–100% control
Special power SPI (HRV / ERV)	0.2 W/(m ³ /h) (280 m ³ /h, 50 Pa)
Special power SFP (HRV / ERV)	0.74 kW/(m ³ /s) or W/(l/s) (280 m ³ /h, 50 Pa)
Condensate connection (mm)	32 mm
Colours	white, black
Packaging	–

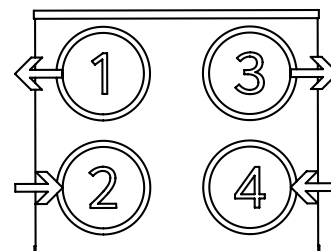
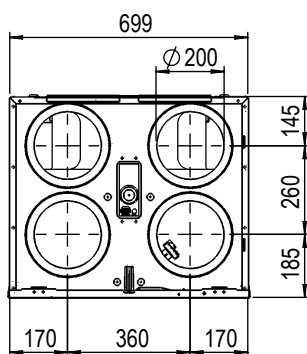
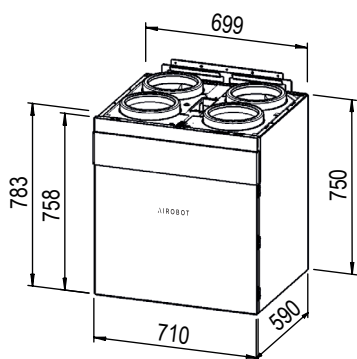

Ducts

TYPE R

1. Supply air
2. Extract air
3. Exhaust air
4. Outside air

TYPE L

1. Exhaust air
2. Outside air
3. Supply air
4. Extract air

AIRobot V6

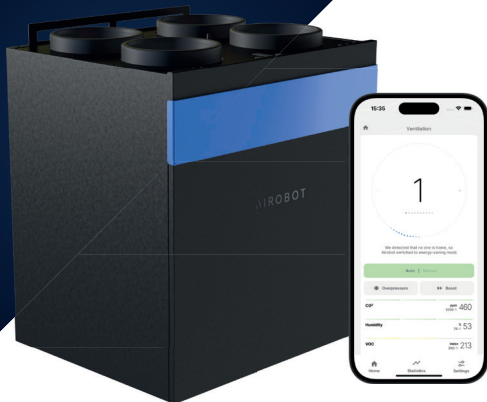

As standard equipment, includes

- constant flow
- integrated CO₂, VOC, air temperature, humidity and PM sensors
- autonomous control – smart control of fans ensures energy efficiency and good indoor air quality
- room occupancy sensing (together with energy saving mode)
- humidity detection mode.

Specifications

Installation	wall-mounted, vertically
Airflow up to	550 m ³ /h or 153 L/s or 250 m ² ventilated area
Heat exchanger	HRV: plate heat exchanger with heat recovery ERV: plate heat exchanger with humidity and heat recovery
Heat recovery efficiency (70% airflow)	TBA
Filters	exhaust air ePM10 55% (M5) / outside air ePM1 55% (F7)
Power supply	1~230 VAC 50 Hz
Maximum power	1.9 kW (10 A)
Fans	2 × 83 W RadiCal EC
Preheater (frost protection)	integrated, nominal power 1.35 kW PTC, 0–100% control
Special power SPI (HRV / ERV)	2.5 W/(m ³ /h)
Special power SFP (HRV / ERV)	0.9 kW/(m ³ /s) or W/(l/s) (385 m ³ /h, 50 Pa)
Condensate connection (mm)	32 mm
Colours	white, black
Packaging	-

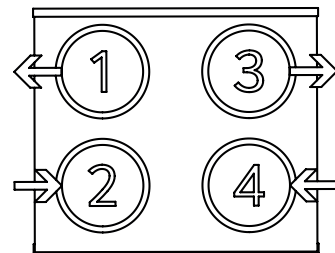
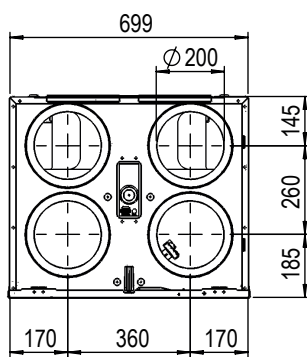
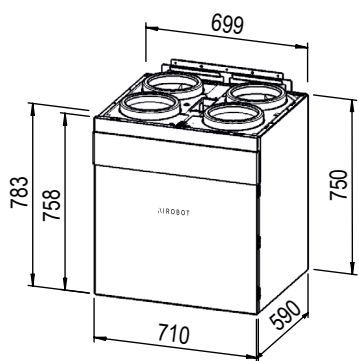

Ducts

TYPE R

1. Supply air
2. Extract air
3. Exhaust air
4. Outside air

TYPE L

1. Exhaust air
2. Outside air
3. Supply air
4. Extract air

AI Robot V8



As standard equipment, includes

- constant flow
- integrated CO₂, VOC, air temperature, humidity and PM sensors
- autonomous control – smart control of fans ensures energy efficiency and good indoor air quality
- room occupancy sensing (together with energy saving mode)
- humidity detection mode.

Specifications

Installation	wall-mounted or floor frame
Airflow up to	750 m ³ /h or 208 l/s or 350 m ² ventilated area
Heat exchanger	HRV: plate heat exchanger with heat recovery ERV: plate heat exchanger with moisture and heat recovery is planned for the end of 2023
Heat recovery efficiency (70% airflow)	V8: 85,4%, V8 ERV: 80,5%
Filters	exhaust air ePM10 55% (M5) / outside air ePM1 55% (F7)
Power supply	1~230 VAC 50 Hz
Maximum power	3,6 kW
Fans	2×170 W RadiCal EC
Preheater (frost protection)	integrated, nominal power 2,7 kW PTC, 0–100% control
Special power SPI (V8 / V8 ERV)	0.25 / 0.25 W/(m ³ /h) ^{525 m³/h / 50 Pa}
Special power SFP (V8 / V8 ERV)	0.917 / 0.917 W/(m ³ /s) ^{525 m³/h / 50 Pa}
Condensate connection (mm)	32 mm
Colours	white, black
Packaging	60 × 103 × 97,5 cm, weight 90 kg

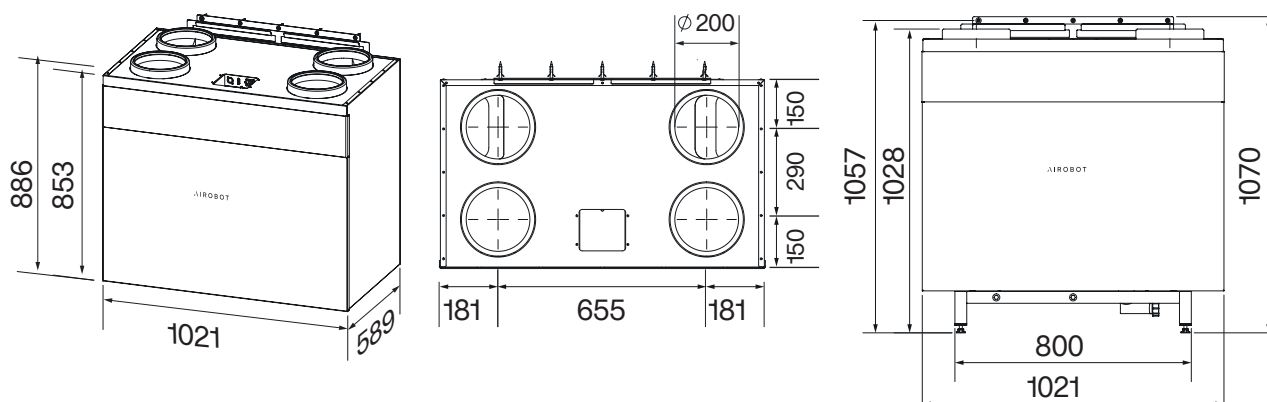

Ducts

TYPE R

1. Supply air
2. Extract air
3. Exhaust air
4. Outside air

TYPE L

1. Exhaust air
2. Outside air
3. Supply air
4. Extract air

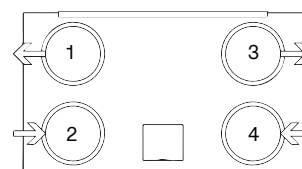

AiRobot Ecosystem

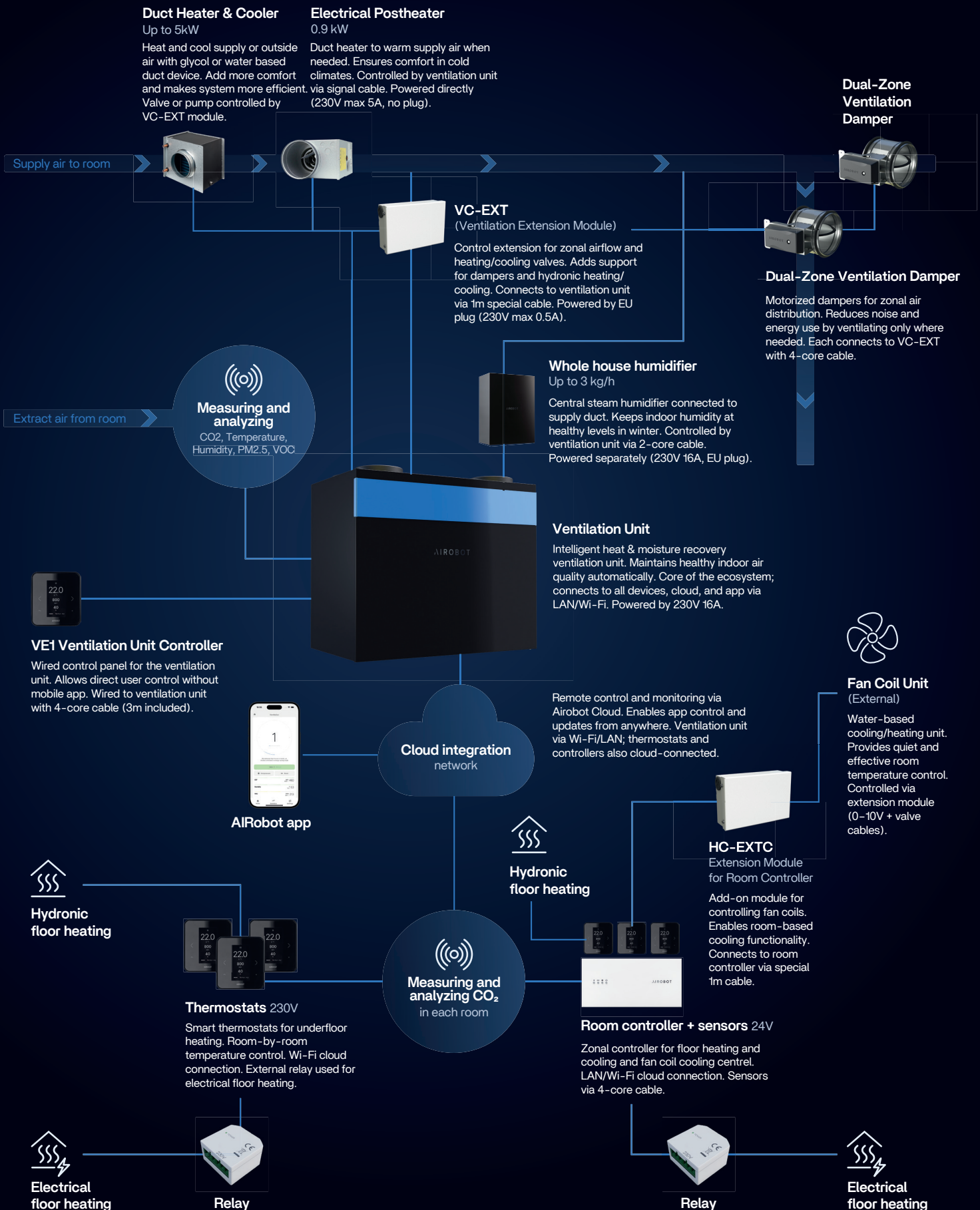

Intelligent ventilation

The AIRobot ventilation device automatically adjusts airflow based on air quality readings.

Dual zone ventilation



At night

Normal airflow to the bedrooms and reduced airflow to living rooms.

Humidity control

The central humidifier add-on to the ventilation device can maintain desired humidity levels automatically.



Central humidifier



Dual zone ventilation

- Minimizes device noise levels
- Uses less energy
- Improves heat recovery efficiency
- Extends system lifespan



Dual zone ventilation



Daytime

Normal airflow to the living rooms and reduced airflow to the bedrooms.

Intelligent heating control

Control heating with Airobot thermostats. Thermostats can be connected to the ventilation device, allowing them to measure CO₂ levels and control the ventilation device via air.

AiRobot

Central air humidifier



Central air humidifiers are used during the **heating season** when humidity can drop to an uncomfortably low level. A central electrode steam humidifier allows its users to **raise and maintain a higher humidity level** in their homes through the ventilation system.

Specifications

Placement	on the wall
Amount of steam produced	up to 3 kg/h
Power supply	1~230 VAC 16 A
Maximum capacity	2,3 kW (10 A)
Power connection	power plug
Steam pipe connection	22 mm
Drainage connection	32 mm, drainage pipe
Condensate nozzle connection	8 mm
Connection to the sewer and water supply	required
Maintenance	regular cleaning or replacement of the steam cylinder must occur every 3000 work hours (one winter period)
Colours	white, black
Dimensions	depth 222 mm, length 366 mm, height 530 mm

Connecting

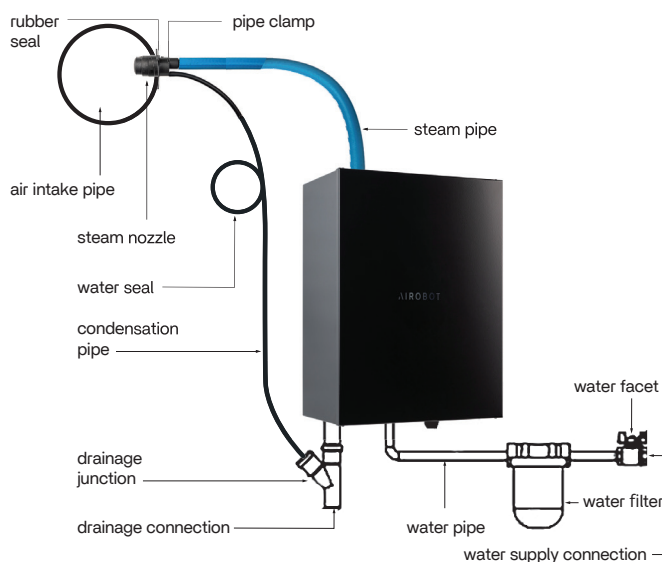

Features

- Allows the user to regulate air humidity in their own home (up to 40%).
- Retains humidity at the desired level.
- Functions only with an Airobot ventilation unit.
- It is necessary to install a supply air sensor (which is included) one meter away from the humidifier nozzle.

Water supply requirements

- A pressure of 1-8 bars.
- The minimum amount of water delivered from the water supply must be 0.6 l/min.
- The minimum amount of water drainage must be 4 l/min.
- The temperature must be between +5 and +40 °C.
- The connection type must be a 3/4" external pipe thread.
- Install a water faucet before installing the device.
- Do not use water softeners – it can lead to corroded electrodes and create foam in the device, which may stop it from functioning as intended.
- The maximum temperature of the water in the drainage system can be up to 100°C. Thermal hazard!

Measurements

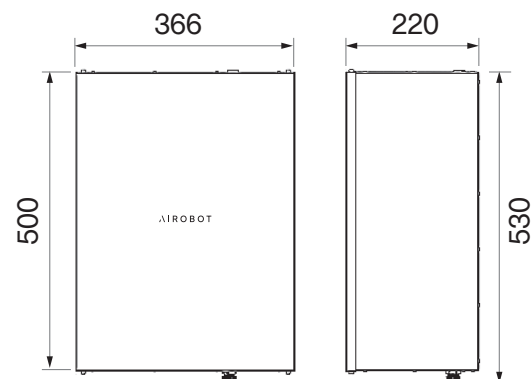

AIRobot

Heating control
Room sensors
with room
controller



Applications

- Water floor heating control
- Water floor cooling control
- Control of electric floor heating (separate relay A-HC-R2416 required)
- Combined control of electric and underfloor heating: simultaneous use with both water and electric underfloor heating.
- Control of water floor heating during the heating season; automatic switch-over to cooling during the summer season. Automatically switches off water floor heating and activates electric floor heating.
- Control of cooling fan (fan-coil) (separate expansion module A-HC-EXTC required).

Specifications

Maximum room sensors	8
Floor temperature sensor	Optional, 10kΩ
Maximum heating zones	8
Maximum actuators	12
Valve actuators	24V, normally closed, max. switching current 0.2 A
Power supply	230 VAC 50/60 Hz. 1 meter EU-plug
Integrated relay 1	24 V, max 0.2 A
Integrated relay 2	Potential free, max. 2 A
Network connection	Wi-Fi 2.4 GHz, LAN
Building automation	Modbus TCP
Dimensions	244x55x120 mm
Room sensor dimensions	82x89x11 mm
Colours	white, black

Room sensor available:

- with temperature and humidity measurement
- with CO², temperature and humidity measurement
- Colours: white, black



Connecting

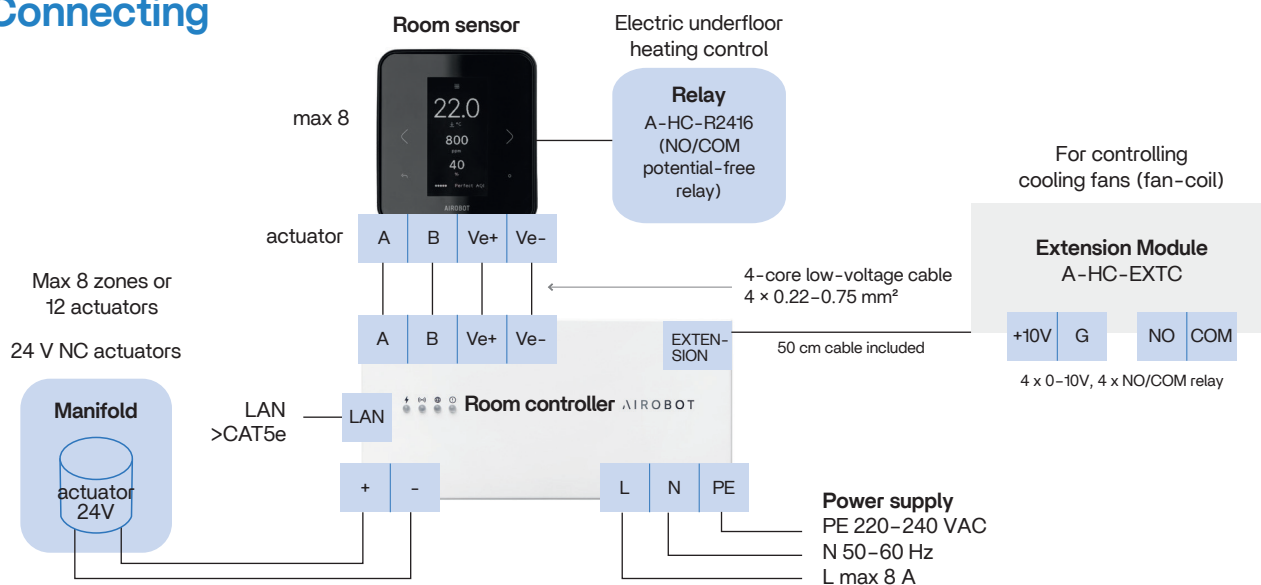

AIRobot

Heating control
thermostat



- AIRobot floor heating thermostats have built-in CO₂ sensors, displaying room temperature, humidity and air quality
- control your heating room by room and adjust the indoor climate comfortably using Airobot app
- AIRobot thermostats and ventilation device can be connected for more precise air quality control

Specifications

Maximum heating zones	1
Maximum actuators	5 pcs
Valve actuators	230 V, normally closed, max. switching current 0.2 A
Power supply	230 VAC 50/60 Hz, 2 × 1.5 mm ² , wall box
Network connection	Wi-Fi 2.4 GHz
Building automation	Local API

Thermostat available:

- with temperature and humidity measurement
- with CO₂, temperature and humidity measurement
- Colours: white, black



Features

- Modern and energy-saving e-paper screen
- Touch sensitive buttons
- Precise control: high-precision (0.2 °C) digital temperature and humidity sensors measure room temperature very precisely and make control more efficient
- "Away" operating mode allows to set up separate set point
- Floor sensor input
- Silent switching: the thermostat does not make a clicking sound
- Regular switching of the actuator during non-heating periods (to avoid scale).

Integration

The AIRobot smart thermostat has an open local API that allows it to integrate with almost all smart home systems very easily and quickly.

Connecting

OPTION A

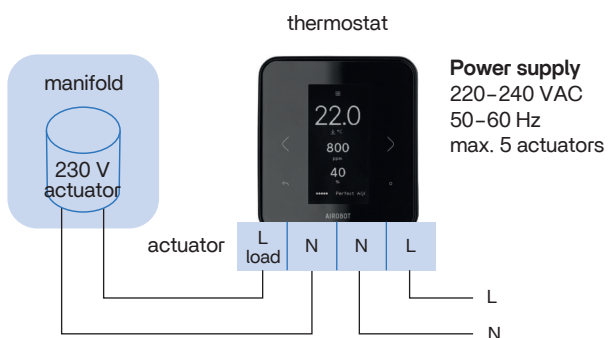

OPTION B

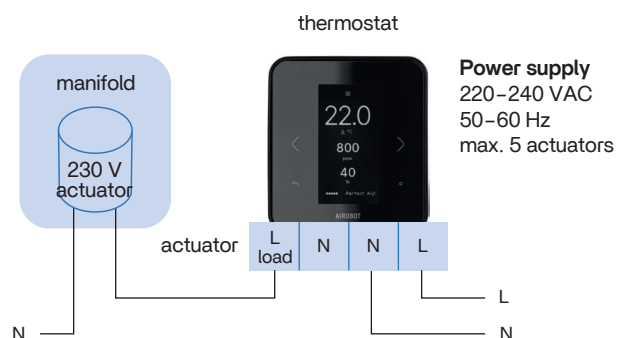

One intuitive app for ventilation and heating control

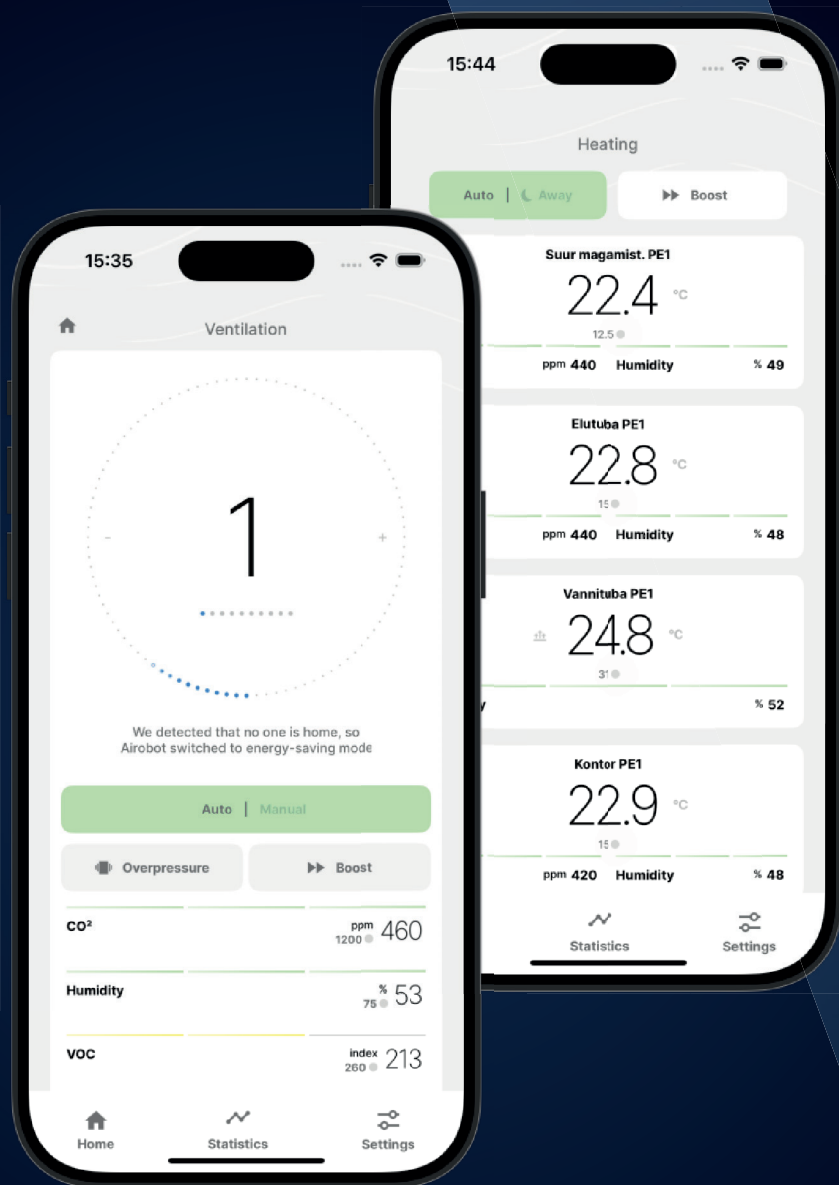

- ▶ **Choose between automatic and manual mode.** In automatic mode the device adjusts ventilation speed according to the CO₂ levels you set.
- ▶ Activate **overpressure** mode for cooking or **boost mode** for an immediate burst of fresh air.
- ▶ **The Airobot app displays real-time air quality data.** You can monitor CO₂, humidity, VOC, and PM levels.
- ▶ Set temperature for each room conveniently from the mobile app from anywhere
- ▶ Set CO₂ maximum levels in bedrooms for a good night's sleep
- ▶ Monitor CO₂ and Humidity in each room for your peace of mind and comfort.

Feedback from customers

“ Considering that I have dust allergy and my daughter is asthmatic, it can be said that Airobot has greatly improved our quality of life.

“ Airobot operates quietly by itself and does a great job adjusting the air quality.

“ We have used our Airobot for a year, and I am satisfied! The air is tip-top.

“ I purchased an Airobot unit. All dealers said that it is far better than other products on the market. And I do not regret the purchase: it is efficient, quiet and well-designed. I can definitely recommend the product.

“ My relative purchased an Airobot unit for their 300 m² home and was very satisfied. The device looks futuristic and high-tech.

AIROBOT

Airobot Technologies AS
sales@airobothome.com
+372 513 3745
airobothome.com