

# AiRobot L

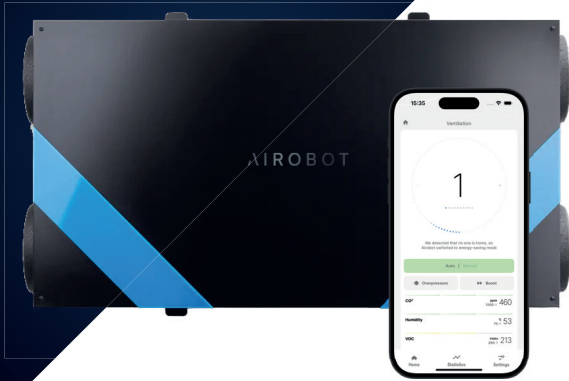

## As standard equipment, includes

- constant flow
- integrated CO<sub>2</sub>, VOC, air temperature, humidity and PM sensors
- autonomous control – smart control of fans ensures energy efficiency and good indoor air quality
- room occupancy sensing (together with energy saving mode)
- humidity detection mode.

## Specifications

<b>Installation</b>	ceiling-mounted, horizontally
<b>Airflow up to</b>	L: 250 m <sup>3</sup> /h với 70 l/s với 120 m <sup>2</sup> ventilated area L ERV: 200 m <sup>3</sup> /h với 55 l/s với 100 m <sup>2</sup> ventilated area
<b>Heat exchanger</b>	HRV: plate heat exchanger with heat recovery ERV: plate heat exchanger with humidity and heat recovery
<b>Heat recovery efficiency</b>	L: 89%, L ERV: 77%
<b>Filters</b>	panel filters, ePM10 55% (M5) / outside air ePM1 55% (F7)
<b>Power supply</b>	1~230 VAC 50 Hz
<b>Maximum power</b>	1.9 kW (10 A)
<b>Fans</b>	2 × 83 W Radical EC Fans
<b>Preheater (frost protection)</b>	integrated, nominal power 1.1 kW PTC, 0–100% control
<b>Special power SPI (L / L ERV)</b>	0.38/0.30 W/(m <sup>3</sup> /h) 175 m <sup>3</sup> /h / 140 m <sup>3</sup> /h 50 Pa
<b>Special power SFP (L / L ERV)</b>	1.36/1.08 W/(m <sup>3</sup> /s) 175 m <sup>3</sup> /h / 140 m <sup>3</sup> /h 50 Pa
<b>Condensate connection (mm)</b>	15 mm, 3 m hose included
<b>Colours</b>	white, black, without metal casing

## Energy labels

### AiRobot L

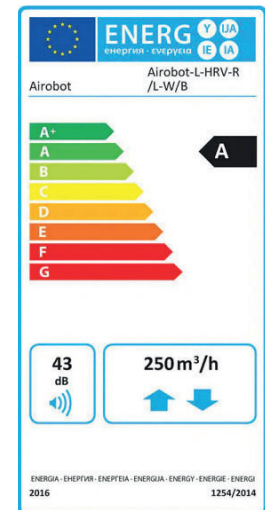

### AiRobot L ERV

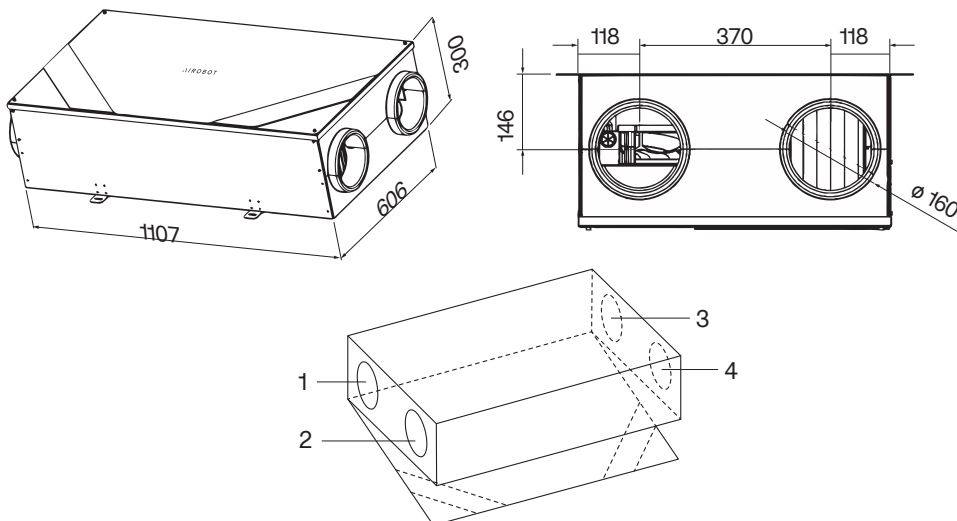
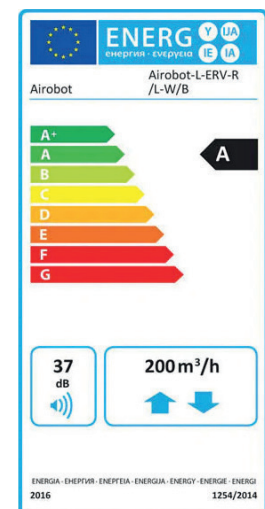

## Ducts

### TYPE R

1. Exhaust air
2. Outside air
3. Supply air
4. Extract air

### TYPE L

1. Supply air
2. Extract air
3. Exhaust air
4. Outside air